



OWNER'S MANUAL

HDII Series • EXII Series • TEII Series • VXFII Series • CMII Series • XPII Series
with NEW RapidLink™

CONTENTS

WELCOME	2
Plow Registration.....	2
SnowDogg® Plow Owner Information.....	3
WARNINGS	4
IMPORTANT APPLICATION NOTICE	5
MOUNTING AND DISMOUNTING	6
STRAIGHT BLADE CONTROLLER OPERATION	7
V BLADE CONTROLLER OPERATION	8
XP PLOW CONTROLLER OPERATION	9
MAINTENANCE	10
Preparing Your Plow for the Season.....	10
Preparing Your Truck for the Season.....	10
In-Season Maintenance.....	11
Preparing Your Plow for Storage.....	11
SNOW PLOW OPERATION	11
Transporting Your Plow.....	12
Plow Smart.....	12
Tactics for Effective Plowing.....	12
Windrowing.....	12
Backdragging.....	13
Stacking.....	13
Other Tips.....	13
Advice for Plowing in Deep Snow.....	13

LIGHT AIMING	14
COMMON SERVICE/MAINTENANCE ITEMS	15
ADDING/CHANGING OIL	16
DROP SPEED ADJUST	16
TROUBLESHOOTING	17
Lighting/Electrical.....	17
General Hydraulics.....	17
Straight Blade.....	19
V Plow.....	20
XP Plow.....	21
Straight Blade Controller Diagnostics.....	23
V Blade Controller Diagnostics.....	24
XP Plow Controller Diagnostics.....	26
WARRANTY INFORMATION	28



WELCOME

Congratulations on your purchase of a SnowDogg® Plow. You have joined a rapidly growing community of Contractors, Maintenance Professionals, Municipalities and Property Owners who are all in on one little secret: When it comes to Snow and Ice removal, Nothing Works Like a Dogg™.

Use this manual to get to know the features of your plow and optimize its operation. With proper use, care and maintenance you can expect your plow to work hard for years to come. When you do need additional support, you can trust your local SnowDogg dealer who has firsthand knowledge of your plow and your local conditions. Buyers Products is proud to partner with the hardest-working dealers in the industry.

PLOW REGISTRATION

Be sure to register your plow at www.buyersproducts.com/support/productregistration. You can also find installation instructions, technical specs and full parts diagrams at www.buyersproducts.com/usermanuals. Required information is detailed on the next page.



SNOWDOGG® PLOW OWNER INFORMATION

Record your plow and installation information here. This information can be used when you register your plow at www.buyersproducts.com/support/productregistration. Registration is required to activate your two year warranty and allows us to reach you with updates and valuable technical information.

REGISTRATION DATA SHEET OWNER'S INFORMATION

Name: _____

Plow Model: _____

Company: _____

Plow Serial#: _____

Address: _____

HPU Serial #: _____

Phone: _____

Fax: _____

Truck Model: _____

E-mail: _____

Truck Year: _____

Purchased From: _____

Purchase Date: _____

REGISTER YOUR PLOW AT WWW.BUYERSPRODUCTS.COM TO ACTIVATE YOUR TWO YEAR WARRANTY.

WARNINGS

WARNING

Read this manual carefully before operating this snowplow.

WARNING

Always follow the vehicle manufacturers recommendations relating to snowplow installation.

WARNING

When using on a vehicle with air bags, DO NOT tamper with, disable or remove any components related to the operation of the air bags.

WARNING

When using on a vehicle with air bags, DO NOT tamper with, disable or remove any components related to the operation of the air bags. Vehicles equipped with air bags are designed such that the air bags will be activated in a frontal collision equivalent to hitting a solid barrier (such as a wall) at approximately 14 mph or more, or, roughly speaking, a frontal perpendicular collision with a parked car or truck of similar size at approximately 28 mph or more. Careless or high speed driving while plowing snow, which results in vehicle decelerations equivalent to or greater than the air bag deployment threshold described above, could deploy the air bag.

WARNING

Make sure plow is properly attached and secured before moving vehicle.

WARNING

Do not move plow while servicing or place any part of your body between or under plow parts while moving plow.

WARNING

When transporting, position plow so as not to block driver line of sight or plow headlights.

WARNING

DO NOT move the blade or exceed 50 MPH when transporting the plow.

WARNING

DO NOT plow at speeds over 14 mph.

WARNING

Always lower blade and power off controller when vehicle is not in use.

IMPORTANT APPLICATION NOTICE

The Snow Plow Selector at www.buyersproducts.com is for reference only. All calculations are based upon the best available information including vehicle curb weights, and truck geometry. It is the operator's responsibility to ensure that the Front Gross Axle Weight Rating (FGAWR), Rear Gross Axle Weight Rating (RGAWR) and Gross Vehicle Weight Rating (GVWR) are not exceeded with the plow and ballast mounted.

Vehicle application recommendations are based on the following:

- The vehicle with the snowplow installed must comply with applicable Federal Motor Vehicle Safety Standards (FMVSS).
- The vehicle with the snowplow installed must comply with the vehicle manufacturer's stated gross vehicle and axle weight ratings (found on the driver-side door corner post of the vehicle) and the front and rear weight distribution ratio. In some cases, rear ballast may be required to comply with these requirements.
- In some cases, there may be additional limitations and requirements.
- Available capacity decreases as the vehicle is loaded with cargo or other truck equipment, or snowplow accessories are installed.
- If there is uncertainty as to whether available capacity exists, the actual vehicle as configured must be weighed.

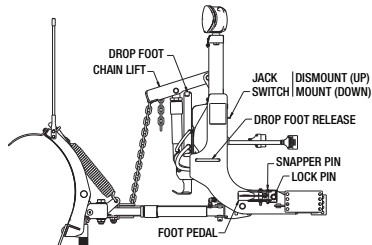

TO MOUNT

1. Enter MOUNT mode: turn the plow controller on and hold DOWN for 1 second. Repeat: hold DOWN again for 1 second. The status indicator will blink red rapidly.
2. Check that the LOCK PINS are fully retracted. If not, push the FOOT PEDAL toward truck to lock pins in a retracted position.
3. Drive into the plow so that the PUSHBAR makes full contact on both sides.
4. Get out of the truck, connect the lighting and hydraulic connectors, and check if PUSHBAR is properly aligned with RECEIVER NOTCH (see diagram 1). If aligned, proceed to step 6.
- 5a. If the plow RECEIVER NOTCH is too low: Back up the truck 6"-12" to allow room to raise the lift frame. Push the JACK SWITCH into DISMOUNT (up) position to raise the rear of the lift frame. If the lift frame ends up sitting too high, follow the instructions in step 5b.
- 5b. If the plow RECEIVER NOTCH is too high to align with the PUSHBAR: Push the JACK SWITCH into MOUNT (down) position to lower the rear of the lift frame. If the lift frame ends up sitting too low, follow the instructions in step 5a.
6. Make a final alignment check. It may be necessary to drive further into the plow for proper engagement.
7. Push the JACK SWITCH into MOUNT (down) position.
8. Press down on the CHAIN LIFT to ensure the lift cylinder is fully retracted. The chain MUST have slack to mount plow.
9. Pull the FOOT PEDAL away from the truck to release the LOCK PINS.
10. Push the center of the light tower towards the truck to mount the plow. The LOCK PINS should extend through the PUSHBAR EARS and be visible on both sides.
11. Insert the SNAPPER PIN to prevent unintended movement of the FOOT PEDAL. If the SNAPPER PIN cannot be inserted, check that the LOCK PINS are fully extended and visible on both sides. If this is not happening, re-check alignment (see diagram 1).
12. Pull the DROP FOOT RELEASE and raise the DROP FOOT to the highest position. Release the DROP FOOT RELEASE and pull up on the DROP FOOT to ensure that it is locked.

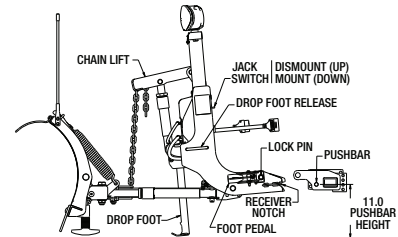

TO DISMOUNT

1. Enter MOUNT mode: turn the plow controller on and hold DOWN for 1 second. Repeat: hold DOWN again for 1 second. The status indicator will blink red rapidly.
2. Press down on the CHAIN LIFT to ensure the lift cylinder is fully retracted. The chain MUST have slack to dismount plow.
3. Pull the DROP FOOT RELEASE and lower the DROP FOOT to the ground. Release the DROP FOOT RELEASE and pull up on the DROP FOOT to ensure that it is locked.
4. Remove the SNAPPER PIN and push the FOOT PEDAL towards the truck to disarm the LOCK PINS.
5. Push the center of the light tower towards the truck until both LOCK PINS retract.
6. **Stand behind the lift frame** and pull up on the JACK SWITCH into DISMOUNT (up) position until the slack is removed from the chain. The plow does not need to tip forward.
7. Disconnect the lighting and hydraulic connectors.
8. Back away from the plow.

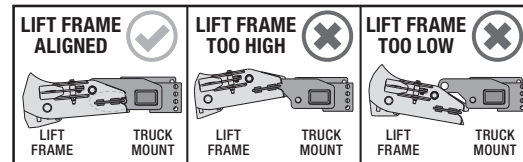
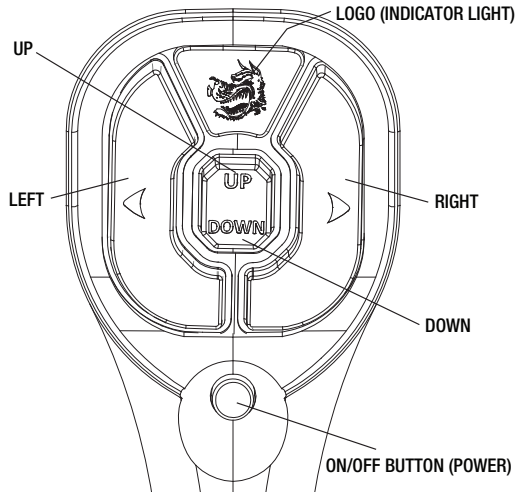

DIAGRAM 1

STRAIGHT BLADE CONTROLLER OPERATION

SnowDogg® straight blade plows feature a simple and intuitive “one-button-per-function” controller design to keep operation simple and intuitive.



Soft Stop

The controller automatically allows the blade to coast to a smooth stop. The feature results in smoother operation and decreased wear on your plow components.

On/Off

Press the POWER button to turn the controller on or off. The indicator light should illuminate green when on. The controller

will automatically turn off after 20 minutes if no buttons are pressed.

Maneuvering the Plow

Press the following buttons to get the desired responses. Plow operations will time out after approximately 3 seconds to prevent excessive current draw.

FUNCTION	OPERATION
UP	Press UP to raise the plow.
DOWN	Press DOWN to lower the plow.
FLOAT	Press DOWN for over a second to engage the plow in FLOAT mode. The indicator light will illuminate blue. FLOAT should always be used when plowing. FLOAT helps reduce loading on the lift frame and chain mechanism. It also allows the plow to follow the contour of the road. Press the UP button to immediately cancel FLOAT mode.
LEFT	Press the LEFT button to angle the plow LEFT by extending the passenger side angle cylinder.
RIGHT	Press the RIGHT button to angle the plow RIGHT by extending the driver side angle cylinder.
MOUNT MODE	Press DOWN for over a second to engage float mode. Repeat: hold DOWN again for over a second to engage MOUNT MODE. The indicator light will flash red.

User Settings

There are a variety of additional user settings available for the controller. Please see the controller instructions for additional details.

V BLADE CONTROLLER OPERATION

SnowDogg® V blade plows feature a simple and intuitive “one-button-per-function” controller design to keep operation simple and intuitive.

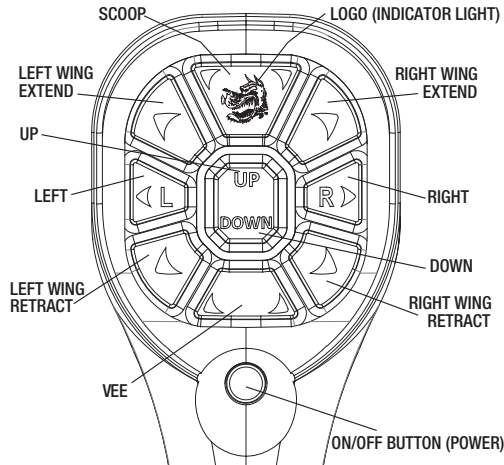

Soft Stop

The controller automatically allows the blade to coast to a smooth stop. The feature results in smoother operation and decreased wear on your plow components.

User Settings

There are a variety of additional user settings available for the controller. Please see the controller instructions for additional details.

On/Off

Press the POWER button to turn the controller on or off. The indicator light should illuminate green when on. The controller will automatically turn off after 20 minutes if no buttons are pressed.

Maneuvering the Plow

Press the following buttons to get the desired responses. Plow operations will time out after approximately 3 seconds to prevent excessive current draw.

FUNCTION	OPERATION
UP	Press UP to raise the plow.
DOWN	Press DOWN to lower the plow.
FLOAT	Press DOWN for over a second to engage the plow in FLOAT mode. The indicator light will illuminate blue. FLOAT should always be used when plowing. FLOAT helps reduce loading on the lift frame and chain mechanism. It also allows the plow to follow the contour of the road. Press the UP button to immediately cancel FLOAT mode.
LEFT/RIGHT RETRACT	Press the RETRACT button that corresponds to the wing of the plow you want to move in, towards the vehicle (V mode).
LEFT/RIGHT EXTEND	Press the EXTEND button that corresponds to the wing of the plow you want to move out, away from the vehicle (scoop).
LEFT	Press the LEFT button to angle both plow wings LEFT.
RIGHT	Press the RIGHT button to angle both plow wings RIGHT.
SCOOP	Press the SCOOP button to extend both wings away from the vehicle (scoop position).
V	Press the V button to retract both wings towards the vehicle (V position).
MOUNT MODE	Press DOWN for over a second to engage float mode. Repeat: hold DOWN again for over a second to engage MOUNT MODE. The indicator light will flash red.

XP PLOW CONTROLLER OPERATION

SnowDogg® XP plows feature a simple and intuitive “one-button-per-function” controller design to keep operation simple and intuitive.

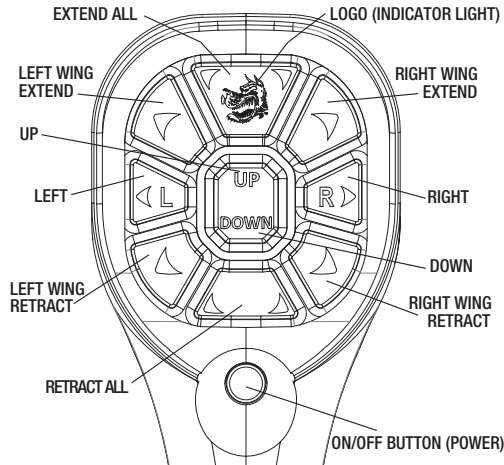

Soft Stop

The controller automatically allows the blade to coast to a smooth stop. The feature results in smoother operation and decreased wear on your plow components.

User Settings

There are a variety of additional user settings available for the controller. Please see the controller instructions for additional details.

On/Off

Press the POWER button to turn the controller on or off. The indicator light should illuminate green when on. The controller will automatically turn off after 20 minutes if no buttons are pressed.

Maneuvering the Plow

Press the following buttons to get the desired responses. Plow operations will time out after approximately 3 seconds to prevent excessive current draw.

FUNCTION	OPERATION
UP	Press UP to raise the plow.
DOWN	Press DOWN to lower the plow.
FLOAT	Press DOWN for over a second to engage the plow in FLOAT mode. The indicator light will illuminate blue. FLOAT should always be used when plowing. FLOAT helps reduce loading on the lift frame and chain mechanism. It also allows the plow to follow the contour of the road. Press the UP button to immediately cancel FLOAT mode.
LEFT/RIGHT RETRACT	Press the RETRACT button that corresponds to the wing of the plow you want to move in .
LEFT/RIGHT EXTEND	Press the EXTEND button that corresponds to the wing of the plow you want to move out .
LEFT	Press the LEFT button to angle the plow LEFT by extending the passenger side angle cylinder.
RIGHT	Press the RIGHT button to angle the plow RIGHT by extending the driver side angle cylinder.
EXTEND ALL	Press the EXTEND ALL button to move both wings out .
RETRACT ALL	Press the RETRACT ALL button to move both wings in .
MOUNT MODE	Press DOWN for over a second to engage float mode. Repeat: hold DOWN again for over a second to engage MOUNT MODE. The indicator light will flash red.

MAINTENANCE

Your SnowDogg® plow as installed by your dealer is ready for use but needs regular maintenance and inspection.

Preparing Your Plow for the Season

Prior to connecting your plow to your truck:

1. Inspect your plow for any damage and make any repairs.

Make sure to examine:

- Welds
- Hydraulic hoses
- Electrical connectors/harnesses
- Rusting areas/damaged paint

2. Ensure hydraulic fittings are properly tightened. Fittings will loosen due to vibrations from normal use.

3. Coat all electrical connection points with dielectric grease.

4. Connect your plow to your truck to continue the inspection:

- Check for proper operation in terms of movement and plow lights.
- Check the aim of your plow lights adjust if necessary. See page 14 for instructions.
- Grease all grease fittings on trip pins and king pin/hinge.
- Drain the hydraulic system and replace with SnowDogg® Low Temp Hydraulic Fluid (#16150010) See page 16 for instructions.
- Check your cutting edges and shoes for wear and replace as necessary.

Preparing Your Truck for the Season

Pushing a plow can be very hard on your truck. Keep up with regular truck maintenance to ensure your truck is ready for the season ahead.

1. Prior to the season, it's **critical** that you have the following checked and repaired as necessary:

- Charging system
- Cooling system
- Lighting system
- Transmission
- Brakes
- Wheel alignment

2. Check the following installation components:

- Ensure all electrical connections are properly tightened. A loose or dirty connection can draw twice as much current as a clean one, which will result in excessive heat and eventual component failure.
- Inspect all harnesses for damage, and repair or replace as necessary.
- Inspect the truck frame/plow mount attachment/push bar and repair or replace as necessary.

3. Curb Weight and Operator Responsibility

- If there is any question about curb weight and/or weight distribution it is always best to ensure that the Front Gross Axle Weight Rating (FGAWR), Rear Gross Axle Weight Rating (RGAWR) and Gross Vehicle Weight Rating (GVWR) are not exceeded with the plow and ballast mounted.

- The ballast and application recommendations at www.buyersproducts.com are for reference only. All calculations are based upon the best available information including vehicle curb weights, and truck geometry. It is the operator's responsibility to ensure safe operation of the vehicle and proper loading. The operator must properly secure ballast when used.

In-Season Maintenance

You rely on your SnowDogg® plow to be at peak performance in the most critical conditions. If you don't want minor issues to turn into major repairs or replacements, then inspect and repair your plow regularly. After every plowing event, follow this easy maintenance check list:

- Check all **weldments** for cracks or incidental damage.
- Check all **linkages** and moving parts for free and smooth operation.
- Inspect **hydraulic hoses** for cracks and damage.
- Check **hoses** for leaks.
- Hand check and tighten all **fittings**.
- Inspect all **connections** for pin damage or evidence of corrosion.
- Ensure that **fasteners**, and plow and **truck mount** are properly torqued.
- Check your **cutting edges** and **shoes** for wear and replace as necessary.

- Ensure all **electrical connections** are properly tightened. A loose or dirty connection can draw twice as much current as a clean one, which will result in excessive heat and eventual component failure.
- Test **plow light** operation.

Preparing Your Plow for Storage

Prior to disconnecting your plow from your truck:

- Extend and grease all chrome cylinder rods.
- Fully compress all cylinders where possible.

After disconnecting your plow from your truck:

- Coat all electrical connection points with dielectric grease.
- Repair/touch up any chipped paint or rusted areas.
- Apply a coat of oil or grease to all exposed chrome on angle and lift cylinders.
- Grease all grease fittings on trip pins and king pin/hinge.

SNOW PLOW OPERATION

Get the most out of your SnowDogg® Plow. Here are a few tips from experts to help you maximize your plow's productivity whether you're just plowing a driveway or plowing a stadium parking lot.

Transporting Your Plow

- Raise your plow blade when transporting your plow. Each truck is different and road conditions vary. Find a height that is high enough to avoid ground contact, but still allows air flow to your radiator and does not block lights.

- Angle the plow blade (in either direction) to help air flow to your radiator.
- Transport your V plow in the “V” position (both wings retracted) to decrease the load on the truck and decrease the plow width for easier maneuvering.
- Always keep an eye on the temperature. If you see your temperature climbing pull over to adjust the plow position. A small position change can make a large difference.
- Always keep the plow in the same position while transporting. DO NOT move the plow during transit. Turn your controller OFF to ensure you do not move the plow accidentally.
- Take some time to get used to maneuvering your vehicle with the plow mounted. Blade guides can help you with visual cues; but practice, experience and time will help you maneuver with ease.

Plow Smart

- Always wear a seat belt while plowing.
- Inspect an area you plan on plowing prior to snowfall. Make a note of potential hazards like sewer grates, speedbumps, exposed pipes and heaved concrete. Even a light snow can hide obstacles that can damage your plow.
- DO NOT plow at speeds that exceed 14 MPH. If you plow at speeds over 14MPH you may cause the truck collision detection/avoidance system to activate and potentially cause airbag deployment.

- Effective stacking can be accomplished at slow speeds. Slamming into piles at high speeds is reckless and can cause needless damage to your plow or truck.

TACTICS FOR EFFECTIVE PLOWING

Windrowing

Windrowing is clearing a wide space (like a parking lot) by creating “windrows” (long piles) of snow and continuing to move them further over with repetitive passes. It allows you to clear a parking lot from one side to another, with the large piles of snow away from the building. Picture a row of cut or mown hay or similar crop.

- Always plow closest to a building first so that you gradually move the snow away from the building.
- Raise your blade and drive to a corner of the parking lot closest to the building.
- Angle your blade away from the building, and drop the blade to plow.
- As you plow straight across the parking lot, you will throw snow forward and away from the building.
- Lift the blade to angle it in other direction, turn around and drop the blade to plow. Repeat.

Backdragging

Backdragging is lowering your plow blade over snow that you want to move, and then dragging it backwards to move it. It is especially useful for plowing driveways, cleaning up and clearing tight spaces.

To backdrag, simply pull up to a building, garage door, or other obstacle with the plow raised. Drop the plow and reverse several truck lengths. You can then back into the cleared area and plow it out or windrow the newly created piles.

Stacking

SnowDogg® plows are ideal for stacking because they feature a chain lift that allow the blades to rise as they go up to a stack. However, only stack when necessary. Excessive stacking is hard on your vehicle and your plow.

Lift the blade as you stack to avoid pulling snow down as you reverse. Stacking should be done at slow speeds—you do not need to slam into a stack. ALWAYS bring your truck to a complete stop prior to shifting into reverse.

OTHER TIPS

Plow with the Storm

It's much easier to continue to plow as the snow builds, rather than waiting to plow at the end of the storm. Large amounts of snow are hard to move, will take many passes and will ultimately hinder your productivity.

Do it Right the First Time

Push all the snow where you need it to be the first time around. If you let it sit in the wrong spot for too long it is likely to freeze and make the next plowing very difficult. If you try to “push back” ice banks that have formed from a

previous plowing, it will put a tremendous and unnecessary load on your plow and truck. Take the time to get it all done right while the snow is still fresh.

ADVICE FOR PLOWING IN DEEP SNOW

Use common sense to limit the load deep snow puts on your plow and truck.

V Plow: V Plows are built to perform in deep snow. Cut a “path” with your plow in V mode. If necessary lift the plow to remove some of the snow. Once you have cleared a path start to extend the wings to widen the cut. Then start to windrow but only use a portion of blade. For example, with 8 in. of snow, you should use no more than half of the blade. Plowing full width in deep snow can damage your transmission and possibly the blade.

Straight Blade: With the right technique, your straight blade is ready to stand up to the deepest snow. Start to cut a “path” by keeping your blade partially raised. Follow the same steps as if you were to windrow and with each pass “scrape off” more snow until you've scraped to the ground. Even trucks that have 4WD can get stuck in deep snow, so make sure to be mindful of what you are driving into.

Always plow in float.

Float allows the plow to stay low and contour the ground.

When the plow is not in flow each obstacle and tripping cause the plow to “yank” the lift chain. This puts undue stress on the plow’s lift frame, mount and the trucks frame.

Have good customer service

Find out where your customer wants the snow to be piled. Customers may need to be reminded that the snow must go somewhere— so make sure they have a realistic idea of where it can go safely. Snow should never block visibility or access to important areas like fire hydrants, mailboxes or public easements.

Follow local regulations

In most places snow cannot be pushed onto other property or onto public streets. In many municipalities snow cannot be pushed across the street. Be sure to check local snow regulations where you are conducting business. Remember, it’s your name on the side of the truck.

LIGHT AIMING

1. Place the vehicle on a level surface 25 feet in front of a matte-white screen, such as a white wall or garage door.
2. The snowplow should be mounted with the blade raised in transport position.
3. Check that the truck is in normal operating condition with no flat tires, failed suspension components and no passengers.

4. Mark the vertical centerline of the vehicle headlights on the screen (a line matching the height the of headlights from the ground). Mark the horizontal centerline of the vehicle headlights on the screen (lines matching the headlight center to center distance).

5. The high intensity zone of the low beams should be just below the horizontal line and to the right of the vertical lines (see figure). Adjust the headlight aim as required.

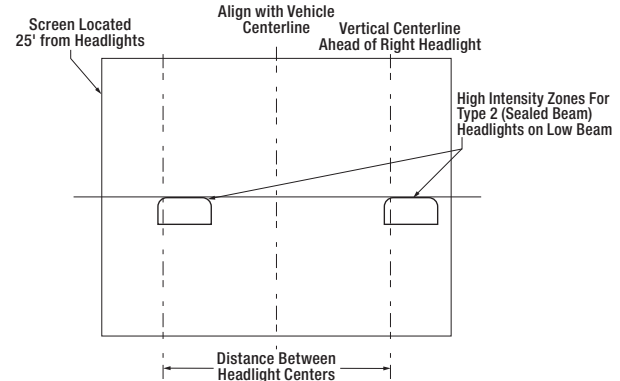

COMMON SERVICE/MAINTENANCE ITEMS

FLUID AND BLADE GUIDES

PART NUMBER	DESCRIPTION
16150010	Low Temp Hydraulic Fluid
16122100	Blade Guide Kit

SHOE ASSEMBLIES

PART NUMBER	DESCRIPTION
16121100	Straight Shoe Assembly
16121700	V Plow Shoe Assembly

EMERGENCY KITS

PART NUMBER	DESCRIPTION
16109020	Straight Plow Emergency Parts Kit
16109030	V-Plow Emergency Parts Kit

PLOW LIGHTS

PART NUMBER	DESCRIPTION
16160710A	DS Plow Light, Halogen
16160720A	PS Plow Light, Halogen
16160810	DS Plow Light, LED
16160820	PS Plow Light, LED

WING KITS

PART NUMBER	DESCRIPTION
16021310	Wing Kit, TE/TE2
16021510	Wing Kit, HD/HD2
16021610	Wing Kit, EX/EX2
16021712	Wing Kit, VXF/VXF2

CUTTING EDGES

PART NUMBER	DESCRIPTION
16120520	90 x 3/8 Steel
16120530	96 x 3/8 Steel
16120610	90 x 1/2 Steel
16120620	96 x 1/2 Steel
16120630	102 x 1/2 Steel
16120640	108 x 1/2 Steel
16120660	108 x 5/8 Steel
16120662	120 x 5/8 Steel
16120664	132 x 5/8 Steel
16120710	90 in. Rubber
16120720	96 in. Rubber
16120730	102 in. Rubber
16120740	108 in. Rubber
16120820	VXF85 Steel
16120830	VXF95 Steel
16120870	VXF105 Steel
16120840	VXF DS Center Steel Edge
16120850	VXF PS Center Steel Edge
16120920	XP Center Steel Edge
16120940	XP DS Steel Edge
16120950	XP PS Steel Edge

BACK DRAG EDGES

PART NUMBER	DESCRIPTION
16124020	Back Drag, 90 in.
16124030	Back Drag, 96 in.
16124040	Back Drag, 102 in.
16124050	Back Drag, 108 in.

DEFLECTORS

PART NUMBER	DESCRIPTION
16120156	90 in. Formed Poly
16120157	90 in. Belted Rubber
16120158	96 in. Formed Poly
16120159	96 in. Belted Rubber
16120160	102 in. Formed Poly
16120161	102 In. Belted Rubber
16120162	108 in. Formed Poly
16120163	108 in. Belted Rubber
16120164	120 in. Belted Rubber
16120165	132 in. Belted Rubber
16120170	VXF85 DS Poly
16120171	VXF85 Rubber (QTY 1)
16120172	VXF85 PS Poly
16120176	VXF95 DS Poly
16120178	VXF95 PS Poly
16120173	VXF95 Rubber (QTY 1)
16120180	VXF Belted Rubber Kit
16122412	XP Deflector Bracket Kit

ADDING/CHANGING OIL

Your SnowDogg® plow comes pre-filled from the factory but due to shipping and handling may require the addition of oil for proper function.

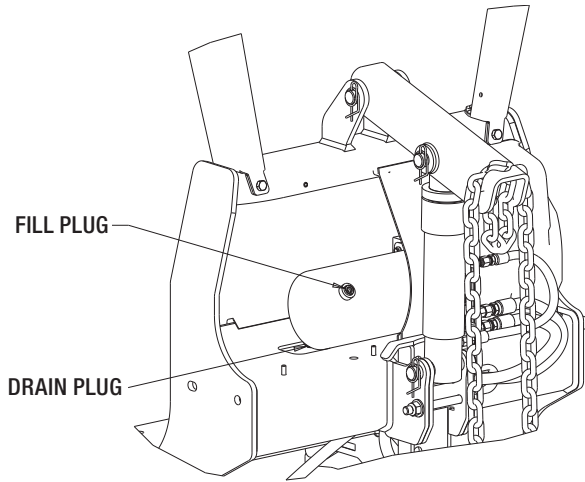

To Add Oil:

1. Make sure the plow is down with the lift cylinder compressed
2. Remove the front passenger side HPU cover
3. Remove the FILL PLUG
4. Add oil until it starts to overflow the FILL PLUG port
5. Reinstall the FILL PLUG

Changing Oil:

1. Compress all cylinders
2. Remove the DRAIN PLUG.
3. Add oil as shown above. SnowDogg® plows take approximately 2 quarts of oil.

If the oil has been contaminated, it is best to remove the reservoir completely to clean the intake screen. This is best left to your dealer.

DROP SPEED ADJUST

The drop speed of the blade is controlled by the LOWERING SPEED VALVE located on the front of the hydraulic power unit (see figure). To increase the drop speed of the blade, use a flat blade screwdriver to turn the valve counter clockwise. Turn it clockwise to slow the blade drop speed. Do this only while the blade is lowered and tighten the jam nut after adjusting.

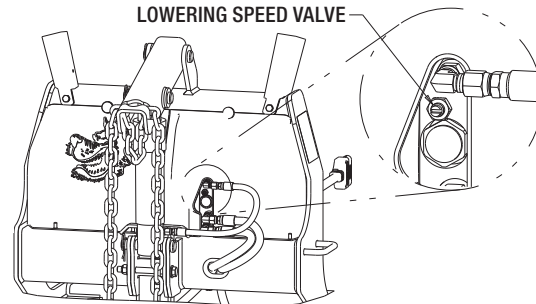

TROUBLESHOOTING

Use the following guide for basic troubleshooting. For more in-depth help, including videos, visit the tech support page at www.buyersproducts.com/techsupport. If you need further assistance please contact your SnowDogg® dealer.

LIGHTING/ELECTRICAL

SYMPTOM	DIAGNOSTIC	RESULT	FIX
Controller not powering up and lights not switching from truck to plow	Check in-line fuse to controller connector	Fuse blown	Replace fuse
		Fuse not blown	Check voltage from truck
Plow starts operating slower while in use	Check vehicle charging system	Low system voltage	Repair vehicle charging system

GENERAL HYDRAULICS

SYMPTOM	DIAGNOSTIC	RESULT	FIX
Plow is not functioning correctly	Controller blinking 3 times rapidly	Go to diagnostic mode (see controller instructions)	Identify the channel at fault and check for continuity to the valve
	Check all connections/harnesses/cables		Repair/replace any damaged connectors or harnesses
Plow moves left and right weakly and will not lift	Check system pressure by putting pressure gage on lift cylinder port and pressing UP	Pressure <1000 PSI	Remove/clean/replace MAIN RELIEF VALVE
Plow drops too slowly/quickly	Check DROP SPEED ADJUST		Adjust DROP SPEED valve in 1/8 turn increments - CCW to drop faster, CW to drop slower (see page 16)
Pump motor not running when UP, LEFT or RIGHT pressed	Apply 12V to small terminal (red wire) on motor solenoid	If motor does not energize, motor solenoid has likely failed	Replace motor solenoid
Plow won't move at all, moves "jerkily", very slowly or chatters	Check fluid level in reservoir	Fluid should be at level of fill port - reservoir should be ~3/4 full	Add fluid
	Air in fluid		In normal operation any excess air should bleed from the system

GENERAL HYDRAULICS, continued

SYMPTOM	DIAGNOSTIC	RESULT	FIX
Oil sprays out of vent port in power unit	Air in fluid	Bleed air from system	In normal operation any excess air should bleed from the system
	Check fluid level in reservoir	Fluid should be at level of fill port - reservoir should be ~3/4 full	Remove fluid if necessary - excess fluid will work its way out through normal operation
Oil is leaking from cylinders	Rod seal is damaged or loose		Replace gland nut w/seal or tighten
Plow drifts while plowing snow	Air in fluid	Bleed air from system	In normal operation any excess air should bleed from the system
	Remove and inspect RELIEF VALVES	Poppet must move freely and seat must be clear of any debris	Remove RELIEF VALVES and clean, replace if necessary
	Remove and inspect CHECK VALVES (V Plow)	Poppet must move freely and seat/piston area must be clear of any debris	Remove CHECK VALVES and clean, replace if necessary
	Remove and inspect ANGLE LOCK VALVE (Straight)		Remove ANGLE LOCK VALVE and check free movement of spool, clean any chips/debris from valve, replace if necessary
	Remove and inspect CROSSOVER RELIEF VALVE (Straight and XP)		Remove CROSSOVER RELIEF VALVE and check free movement of spool, clean any chips/debris from valve, replace if necessary

STRAIGHT BLADE

SYMPTOM	DIAGNOSTIC	RESULT	FIX
Plow won't drop	Check voltage at SA VALVE (blue wire)	No voltage	Replace/repair cable or connections
		Voltage present	Replace coil and then valve if necessary
Plow won't stay up in transport	Remove and inspect SA VALVE	Poppet must move freely and seat area must be clear of any debris	Remove SA VALVE and check free movement of poppet, clean any chips/debris from poppet seat, replace if necessary
	Remove and inspect LIFT LOCK VALVE	Poppet must move freely and seat area must be clear of any debris	Remove LIFT LOCK VALVE and check free movement of poppet, clean any chips/debris from poppet seat, replace if necessary
Plow won't lift	Check voltage at SB VALVE (green wire)	No voltage	Replace/repair cable or connections
		Voltage present	Replace coil and then valve if necessary
	Remove and inspect SB VALVE	Spool must move freely	Remove SB VALVE and check free movement of spool, clean any chips/debris from valve
Plow won't angle right or left	Check voltage at SC VALVE (orange wire)	No voltage	Replace/repair cable or connections
		Voltage present	Replace coil and then valve if necessary
	Remove and inspect SC VALVE	Spool must move freely	Remove SC VALVE and check free movement of spool, clean any chips/debris from valve
	Remove and inspect ANGLE LOCK VALVE		Remove ANGLE LOCK VALVE and check free movement of spool, clean any chips/debris from valve

V PLOW

SYMPTOM	DIAGNOSTIC	RESULT	FIX
Plow won't drop	Check voltage at S1B VALVE (purple wire)	No voltage	Replace/repair cable or connections
		Voltage present	Replace coil and then valve if necessary
Plow won't stay up in transport	Remove and inspect S1B VALVE	Poppet must move freely and seat area must be clear of any debris	Remove S1B VALVE and check free movement of poppet, clean any chips/debris from poppet seat, replace if necessary
	Remove and inspect LIFT LOCK VALVE	Poppet must move freely and seat area must be clear of any debris	Remove LIFT LOCK VALVE and check free movement of poppet, clean any chips/debris from poppet seat, replace if necessary
Plow won't lift	Check voltage at S1A VALVE (blue wire)	No voltage	Replace/repair cable or connections
		Voltage present	Replace coil and then valve if necessary
Wings SCOOP when RIGHT OUT is pressed	See if S2A/S2B coils are tight on the valve stems	Hard to remove	Valve is damaged and should be replaced
		Easy to remove	Check voltage at valve
	Check voltage at S2A/S2B VALVES (green wire)	No voltage	Replace/repair cable or connections
Wings SCOOP when LEFT OUT is pressed	See if S2A/S2B coils are tight on the valve stems	Voltage present	Replace coil and then valve if necessary
		Hard to remove	Valve is damaged and should be replaced
	Check voltage at S3A/S3B VALVES (orange wire)	Easy to remove	Check voltage at valve
		No voltage	Replace/repair cable or connections
		Voltage present	Replace coil and then valve if necessary

V PLOW, continued

SYMPTOM	DIAGNOSTIC	RESULT	FIX
Left or right wing won't extend	Check voltage at S4 (LEFT-blue/white) or S5 (RIGHT-blue/white) VALVES	No voltage	Replace/repair cable or connections
		Voltage present	Replace coil and then valve if necessary
	Remove and inspect S4/S5 VALVES	Poppet must move freely and seat area must be clear of any debris	Remove S4/S5 VALVE and check free movement of poppet, clean any chips/debris from valve
Left or right wing won't retract	Check voltage at S6 (LEFT-green/white) or S7 (RIGHT- orange/white) VALVES	No voltage	Replace/repair cable or connections
		Voltage present	Replace coil and then valve if necessary
	Remove and inspect S6/S7 VALVES	Poppet must move freely and seat area must be clear of any debris	Remove S6/S7 VALVE and check free movement of poppet, clean any chips/debris from valve

XP PLOW

SYMPTOM	DIAGNOSTIC	RESULT	FIX
Plow won't drop	Check voltage at S1B VALVE (purple wire)	No voltage	Replace/repair cable or connections
		Voltage present	Replace coil and then valve if necessary
Plow won't stay up in transport	Remove and inspect S1B VALVE	Poppet must move freely and seat area must be clear of any debris	Remove S1B VALVE and check free movement of poppet, clean any chips/debris from poppet seat, replace if necessary
	Remove and inspect LIFT LOCK VALVE	Poppet must move freely and seat area must be clear of any debris	Remove LIFT LOCK VALVE and check free movement of poppet, clean any chips/debris from poppet seat, replace if necessary

XP PLOW, continued

SYMPTOM	DIAGNOSTIC	RESULT	FIX
Plow won't lift	Check voltage at S1A VALVE (blue wire)	No voltage	Replace/repair cable or connections
		Voltage present	Replace coil and then valve if necessary
Plow won't angle right or left	Check voltage at S2 (LEFT-green) or S3 (RIGHT-orange) VALVES Remove and inspect S2/S3 VALVES	No voltage	Replace/repair cable or connections
		Voltage present Poppet must move freely and seat area must be clear of any debris	Replace coil and then valve if necessary Remove S2/S3 VALVE and check free movement of spool, clean any chips/debris from valve
Left and right wings won't extend	Check voltage at S4 VALVE (blue/white wire) Remove and inspect S4 VALVE	No voltage	Replace/repair cable or connections
		Voltage present Poppet must move freely and seat area must be clear of any debris	Replace coil and then valve if necessary Remove S4 VALVE and check free movement of spool, clean any chips/debris from valve
Left wing won't extend or retract	Check voltage at S5 VALVE (green/white wire) Remove and inspect S5 VALVE	No voltage	Replace/repair cable or connections
		Voltage present Poppet must move freely and seat area must be clear of any debris	Replace coil and then valve if necessary Remove S5 VALVE and check free movement of spool, clean any chips/debris from valve
Right wing won't extend or retract	Check voltage at S6 VALVE (orange/white wire) Remove and inspect S6 VALVE	No voltage	Replace/repair cable or connections
		Voltage present Poppet must move freely and seat area must be clear of any debris	Replace coil and then valve if necessary Remove S6 VALVE and check free movement of spool, clean any chips/debris from valve

STRAIGHT BLADE CONTROLLER DIAGNOSTICS

Diagnostic Mode

If this controller detects an issue with the snowplows wiring system, the indicator light will blink Red 3 times repeatedly. To determine the issue, go to the Diagnostic Mode. To enter Diagnostic Mode (turn vehicle's ignition ON):

1. Turn the control OFF.
2. Press & Hold the UP button, then Press & Release the ON/OFF button. Then, release the Up button.
3. You are now in Diagnostic Mode (Channel 1) & all outputs are OFF (the plow will only function during the "short" test).

Blue Indicator Light

- A long blink indicates a starting point for the selected channel.

Green Indicator Light

- Blinks the number of the selected channel.

Red Indicator Light

- Blinks 4 times to indicate the selected channel is open (broken).
- Solid (in "short" test) indicates the selected channel is shorted.

Short test

When you are in any channel, you can test to see if that channel is shorted by pressing and holding the UP button (Warning: The plow can move). If, while holding the UP button, the indicator light shows solid Red, that channel has a short.

Diagnostic Mode Button Configuration

RIGHT = Increase channel #

LEFT = Decrease channel #

UP = Turns ON selected channel (short test)

ON/OFF = Exit Diagnostic Mode

LOGIC TABLE				
CHANNEL	1	2/5	3/6	4/7
VALVE	MOTOR	SA	SB	SC
		DROP	LIFT/ANGLE	ANGLE
	RED	BLUE	GREEN	ORANGE
UP	1		1	
DOWN		1		
FLOAT		1		
LEFT	1			
RIGHT	1			1

V BLADE CONTROLLER DIAGNOSTICS

Diagnostic Mode

If this controller detects an issue with the snowplows wiring system, the indicator light will blink Red 3 times repeatedly. To determine the issue, go to the Diagnostic Mode. To enter Diagnostic Mode (turn vehicle's ignition ON):

1. Turn the control OFF.
2. Press & Hold the UP button, then Press & Release the ON/OFF button. Then, release the Up button.
3. You are now in Diagnostic Mode (Channel 1) & all outputs are OFF (the plow will only function during the "short" test).

Blue Indicator Light

- A long blink indicates a starting point for the selected channel.

Green Indicator Light

- Blinks the number of the selected channel.

Red Indicator Light

- Blinks 4 times to indicate the selected channel is open (broken).
- Solid (in "short" test) indicates the selected channel is shorted.

Short test

When you are in any channel, you can test to see if that channel is shorted by pressing and holding the UP button (Warning: The plow can move). If, while holding the UP button, the indicator light shows solid Red, that channel has a short.

Diagnostic Mode Button Configuration

RIGHT = Increase channel #

LEFT = Decrease channel #

UP = Turns ON selected channel (short test)

ON/OFF = Exit Diagnostic Mode

V CONTROLLER OUTPUT TABLE								
PIN	MOTOR	A	B	C	D	E	F	G
CHANNEL	#1	#2	#3	#4	#5	#6	#7	#8
VALVE	MOTOR	S1A	S2A/B	S3A/B	S4/S5	S6	S7	S1B
UP	X	X						
DOWN								X
FLOAT								X
LEFT IN	X					X		
LEFT OUT	X			X	X			
RIGHT IN	X						X	
RIGHT OUT	X		X		X			
VEE	X					X	X	
SCOOP	X				X			
ANGLE LEFT	X			X				
ANGLE RIGHT	X		X					

XP PLOW CONTROLLER DIAGNOSTICS

Diagnostic Mode

If this controller detects an issue with the snowplows wiring system, the indicator light will blink Red 3 times repeatedly. To determine the issue, go to the Diagnostic Mode. To enter Diagnostic Mode (turn vehicle's ignition ON):

- 1.** Turn the control OFF.
- 2.** Press & Hold the UP button, then Press & Release the ON/OFF button. Then, release the Up button.
- 3.** You are now in Diagnostic Mode (Channel 1) & all outputs are OFF (the plow will only function during the "short" test).

Blue Indicator Light

- A long blink indicates a starting point for the selected channel.

Green Indicator Light

- Blinks the number of the selected channel.

Red Indicator Light

- Blinks 4 times to indicate the selected channel is open (broken).
- Solid (in "short" test) indicates the selected channel is shorted.

Short test

When you are in any channel, you can test to see if that channel is shorted by pressing and holding the UP button (Warning: The plow can move). If, while holding the UP button, the indicator light shows solid Red, that channel has a short.

Diagnostic Mode Button Configuration

RIGHT = Increase channel #

LEFT = Decrease channel #

UP = Turns ON selected channel (short test)

ON/OFF = Exit Diagnostic Mode

XP CONTROLLER OUTPUT TABLE								
PIN	MOTOR	A	B	C	D	E	F	G
CHANNEL	#1	#2	#3	#4	#5	#6	#7	#8
VALVE	MOTOR	S1A	S2	S3	S4	S5	S6	S1B
UP	X	X						
DOWN								X
FLOAT								X
LEFT IN	X				X	X		
LEFT OUT	X					X		
RIGHT IN	X				X		X	
RIGHT OUT	X						X	
ANGLE LEFT	X		X					
ANGLE RIGHT	X			X				
EXTEND ALL	X					X	X	
RETRACT ALL	X				X	X	X	

LIMITED WARRANTY COVERAGE

Buyers Products Company warrants to the original purchaser of a Buyers Products SnowDogg® brand snowplow that they will be free from defects in materials and workmanship for a period of two (2) years after the date of original purchase. Buyers Products warrants accessories, service parts, and components purchased separately to be free of defects in materials and workmanship for a period of one (1) year after date of original purchase. These warranties are exclusive and in lieu of all other express and, except to the extent prohibited by applicable law, all implied warranties, including but not limited to the implied warranties of merchantability and fitness for a particular purpose, are limited in duration to the duration of this warranty. Buyer Product's Liability is expressly limited to repair or replacement of defective parts. Buyers Products shall not be liable for consequential, incidental or contingent damages whatsoever, even if damages are caused by the negligence or fault of Buyers Products. This warranty gives you specific legal rights. Additional purchaser's rights may vary from state to state.

WHAT IS NOT COVERED

The warranty does not apply to:

- parts not furnished by Buyers Products or damage resulting from same.
- parts modified without authorization or damage resulting from same.
- expendable parts (cutting edges, fluids, etc.).
- damage resulting from failure to install, maintain or operate the product per the owner's manual, installation instructions, or application guides.
- damage to vehicle and/or frame of vehicle resulting from plow attachment.

WARRANTY PROCEDURE

If any part is proven to be defective within that warranty period, Buyers Products will, at its sole discretion, repair or replace said part at its expense FOB Cleveland, OH. Labor will be credited to authorized dealers as determined by published rate charts. Buyers Products obligation shall be limited to such repair or replacement and shall be further contingent on Buyers Products receiving written notice of the alleged defect and proof of original purchase within ten (10) days of its discovery as well as the return of the allegedly defective part to Buyers Products. To obtain service, the purchaser must return the defective snowplow to an authorized SnowDogg Dealer® with proof of purchase and applicable maintenance records. All transportation costs to and from the dealer will be the responsibility of the purchaser. SnowDogg® dealers may be located on-line at www.buyersproducts.com/dealerlocator.

Contact Your Dealer for Service and Technical Support.

LED Lighting

With more lighting choices than anyone else, we make it easy to light up your work vehicles.



the ALL NEW SaltDog® **PRO** Series

Available in 2 cubic yard and 2-1/2 cubic yard capacity, with auger or chain drive options available.



www.BuyersProducts.com

The Buyers family of manufacturing compaines

Tracom

RomoTech
Rotational Molding Technologies, Inc.

P
PROGRESSIVE
POWDER COATING, INC.

B Boomerang
RUBBER, INC.

Buyers
PRODUCTS COMPANY

SnowDogg
by Buyers

SaltDogg
by Buyers

ScoopDogg
by Buyers

DumperDogg
by Buyers



3046131_A

